

| Motortyp <i>Motor type</i> | Treibscheibe <i>Traction sheave</i> Ø D1 mm | Seilrolle <i>Diverter pulley</i> Ø D2 mm | ASL min - max. mm |
|-------------------------------|---|--|----------------------|
| SM160.20/30B/40B | 160 | 160 | 420 - 1060 |
| SM160.20/30B/40B | 240 | 240 | 420 - 1140 |
| SM200.15C/20C/30C | 240 | 240 | 420 - 1140 |
| SM200.15C/20C/30C | 320 | 320 | 500 - 1220 |
| SM200.15C/20C/30C | 400 | 400 | 500 - 1260 |
| SM200.40C/45D | 160 | 160 | 420 - 1060 |
| SM200.40C/45D | 240 | 240 | 420 - 1140 |
| SM200.40C/45D | 320 | 320 | 500 - 1220 |
| SM200.40C/45D | 400 | 400 | 500 - 1260 |
| SM200.40C/45D | 500 | 520 | 500 - 1280 |
| SM225.40B/45C | 240 | 240 | 420 - 1100 |
| SM225.40B/45C | 320 | 320 | 580 - 1180 |
| SM225.40B/45C | 400 | 400 | 580 - 1260 |
| SM225.40B/45C | 500 | 520 | 610 - 1330 |

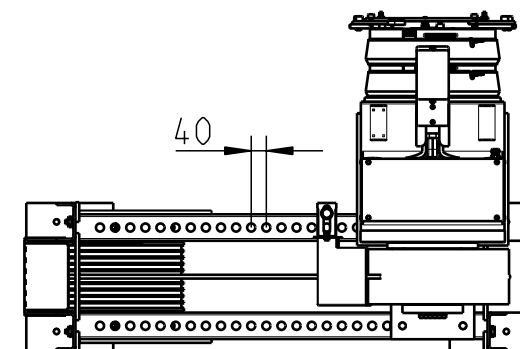
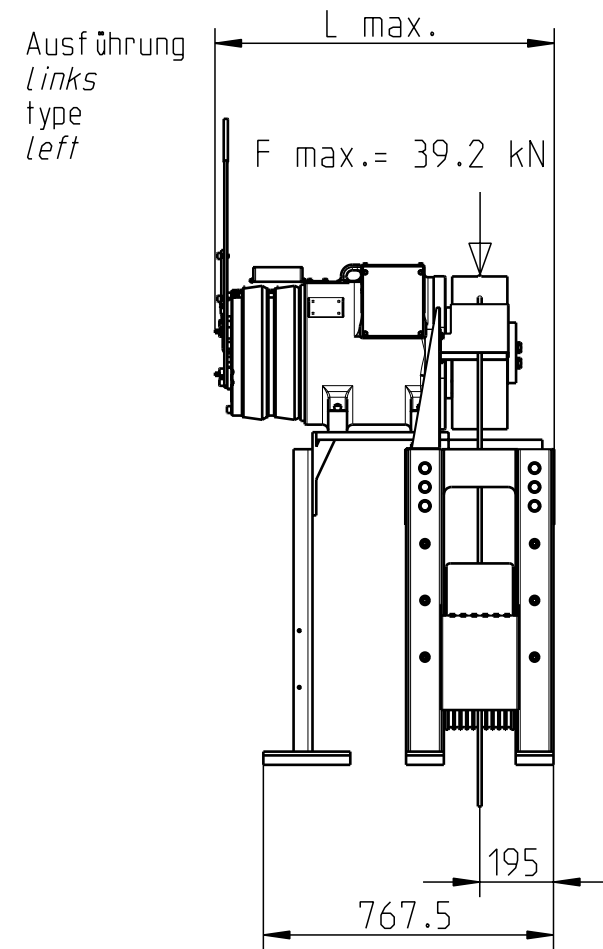
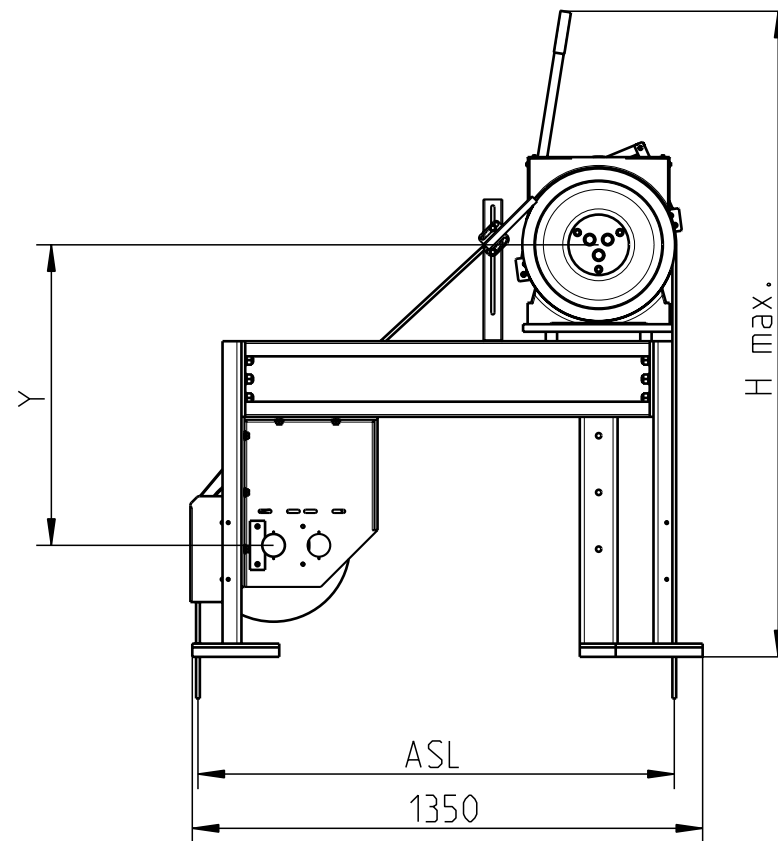
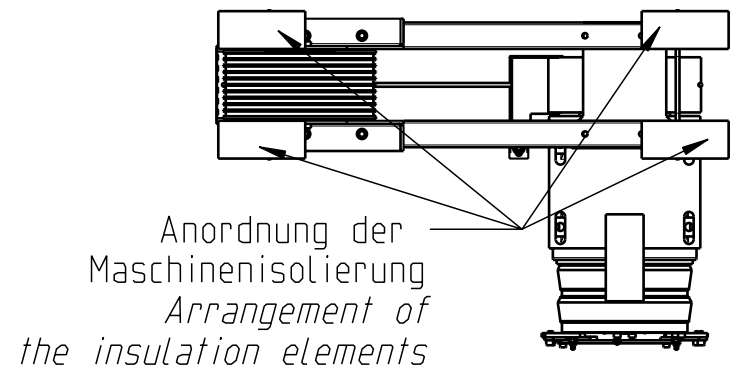

Gewicht Rahmen ohne Motor und Seilrolle: 160 kg
Weight frame without machine and diverter pulley: 160 kg

| Motortyp <i>Motor type</i> | Y mm | H max. mm | L max. mm |
|-------------------------------|---------|--------------|--------------|
| SM160.20/30B/40B | 774 | 1492 | 810 |
| SM200.15C/20C/30C | 680 | 1323 | 763 |
| SM200.40C/45D | 797 | 2045 | 879 |
| SM225.40B/SM225.45C | 795 | 1800 | 905 |

| | | | | | |
|--|--|---|---|---------------------------------------|---|
| ZIEHL-ABEGG ZIEHL-ABEGG SE Heinz-Ziehl-Straße 74653 Kuenzelsau Germany Tel. +49 7940 16-0 www.ziehl-abegg.com | Darstellung schematisch gezeichnet - Änderungen vorbehalten <i>schematical drawn image - subject to modifications</i> | | Benennung <i>title</i> ZAframe MH4000 | | |
| | Index <i>index</i> A03 | Änderung <i>revision</i> A17_0062 | Datum <i>date</i> 07.04.2017 | Name <i>name</i> Schoch | |
| | This drawing is property of ZIEHL-ABEGG SE. The reproduction, distribution and utilization is subject to authorization. All rights reserved. | | erstellt <i>drawn</i> 08.04.2016 | scho | Zeichnungsnummer <i>drawing number</i> A-M-6626 |
| | | | geprüft <i>checked</i> Schoch | Maße in mm <i>dimensions in mm</i> | |